



Focus Track System Owner's Manual

870 Bunting Ln
Bldg. A
Primos, PA 19018

800-727-7471
www.sapsis-rigging.com

© Copyright 2022 Sapsis Rigging, Inc. All rights reserved.

SAPSIS RIGGING FOCUS TRACK SYSTEM

Assembly Instructions - Track and Trolley

- Focus Tracks are provided in one of two style - I-Beam and T-Beam Please see following pages for illustrations of the two different types.
- The track sections are drilled to accept splices or end stops uniformly. All sections should fit, no matter what order they are put together.
- Suspend the track sections from the structure (building steel, pipe batten, truss cord, etc.) in individual sections with the hardware provided.

Note: Maximum span between hanging points with I-beam track is 10'-0"
Maximum span between hanging points with T-beam track is 5'-0"

- Bolt the track sections together with the splice plates per the supplied drawing. There are two plates and twelve (12) 3/8"Ø x 1.25" hex head bolts w/nylocks per splice.
- Place the chair trolley onto the track making sure all three beam trolley wheels engage the track. The wheel assemblies can be rotated by hand to ensure that all wheels are running on the track. It is not necessary to disassemble the chair trolley to install it. The beam trolley wheel spacing has been set by SRI and needs no adjustment.
- Bolt the end stops onto the track using the supplied hardware per the supplied drawing. There are two 3/8"Ø x 1.5" hex head bolts w/nylocks per end stop.
- Hang the chair from the trolley with the attached hardware. The chair should hang from the end trolleys.
- Hang the Self Retracting Device (SRD) from the middle beam trolley.

Assembly Instructions - Operator Pull Line

- An Operator Pull Line is provided with your Focus Track so that you can pull yourself along the Focus Track. Please see following pages for an illustration of the Operator Pull Line assembly.
- Attach one Operator Pull Line Bracket on the bottom flange of each end of the I or T Beam. Position the brackets so that the eyebolts and Operator Pull Line will be in front of the person in the Focus Trolley.
- Secure the brackets using the metal clips (clamps) and bolts provided.
- Tie the 1/2" cord to the eyebolts provided on the brackets, using two half hitches.
- Trim and secure the loose ends of the line using high quality electrical tape, self-fusing silicone tape (Rescue tape), or a minimum of two cable ties ("zip-ties"). This will prevent the cord from coming untied or fouling in adjacent equipment.



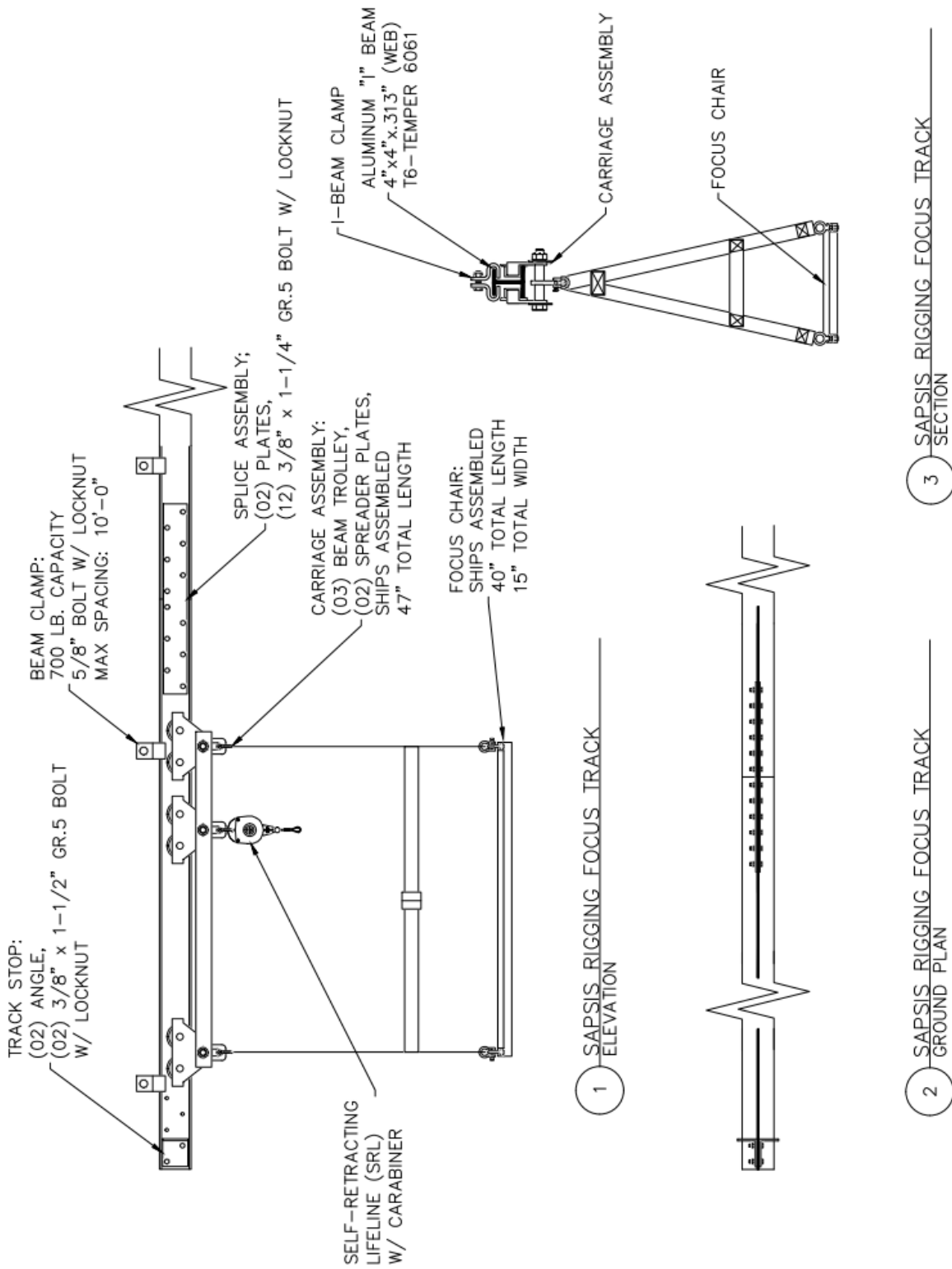

Focus Track I-Beam Style



800-727-7471 • www.sapsis-rigging.com • sales@sapsis-rigging.com

870 Bunting Ln Bldg A Primos, PA 19018 •

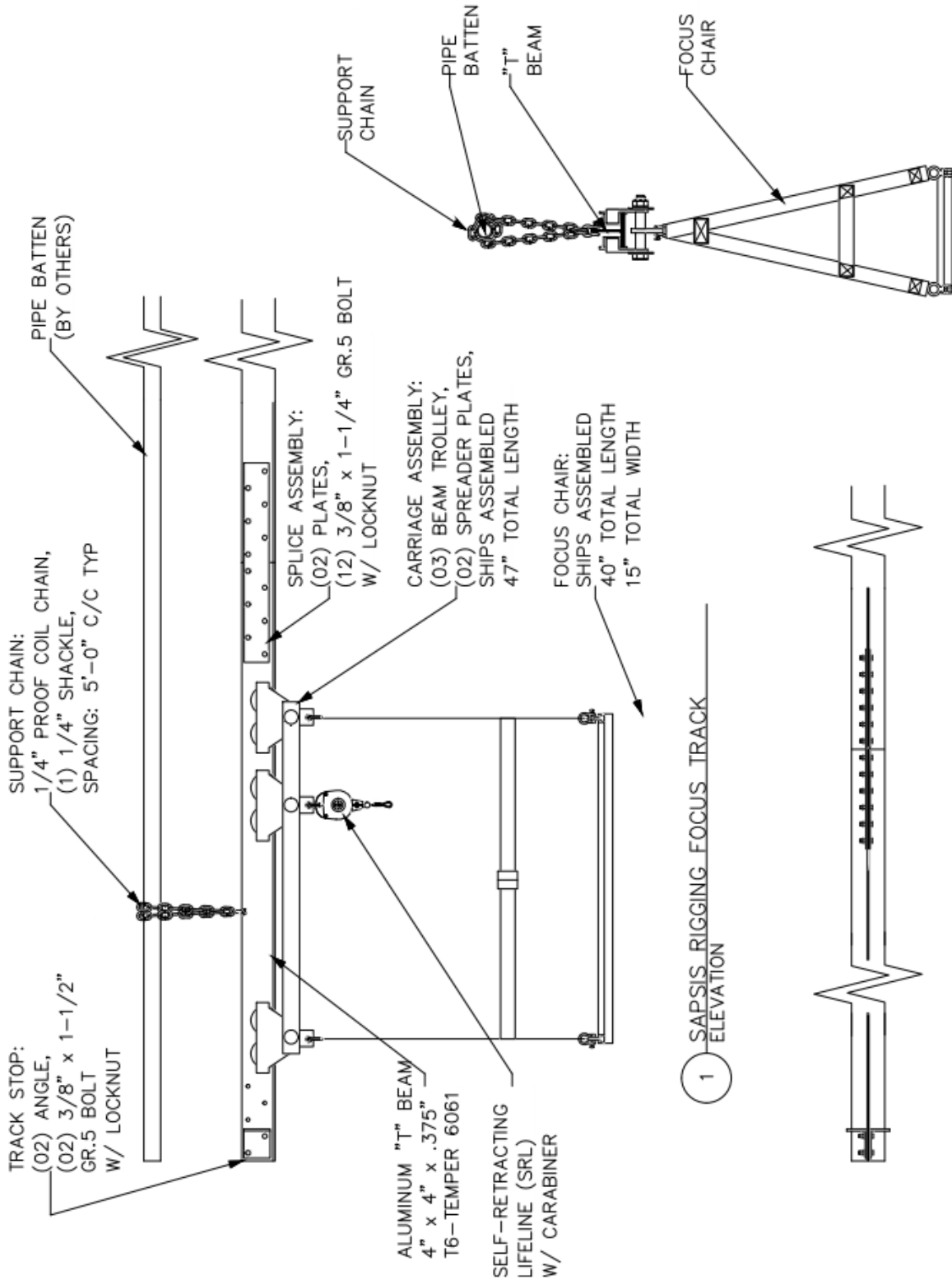

Focus Track T-Beam Style



800-727-7471 • www.sopsis-rigging.com • sales@sopsis-rigging.com

870 Bunting Ln Bldg A Primos, PA 19018 •

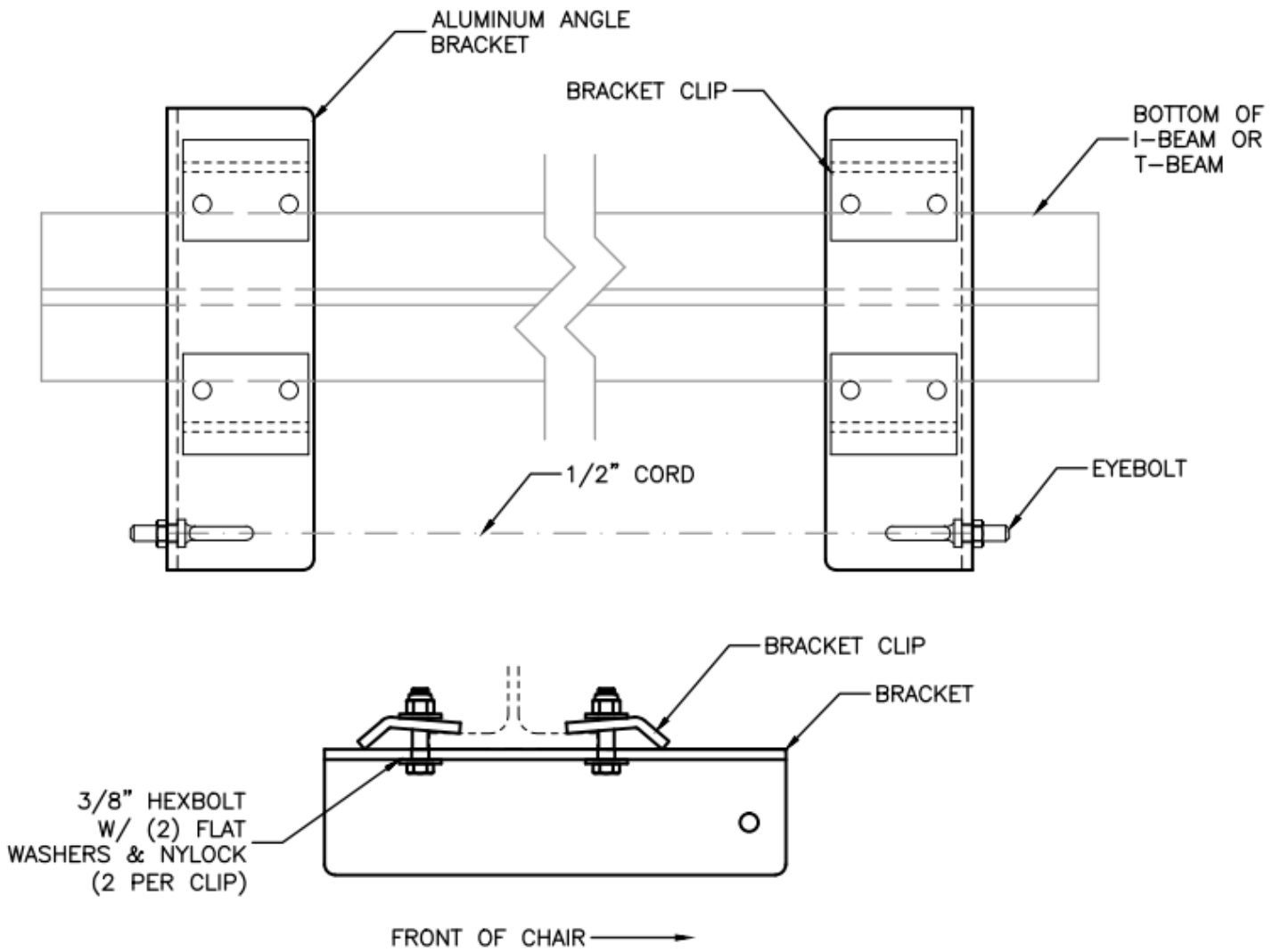

Focus Track Operator Pull Line Assembly

Maintenance and Inspection

- The entire assembly must be inspected prior to each installation and use. All worn or non-functioning parts must be immediately removed from service and replaced.

NOTE: If you can tighten a nylock hex nut all the way onto the hex bolt by hand, the nylon insert has worn out. The nylok hex nut must be replaced.

- All trolleys wheels must rotate freely. Please note, however, that the bearings are sealed and there's no place to apply lubrication. If a problem develops, please contact Sapsis Rigging.
- The Self Retracting Device (SRD) must be inspected prior to each use.
- Seat suspension webbing and hardware must be checked for wear. Worn, torn or damaged webbing must be immediately removed from service and replaced.
- Keep all equipment away from heat. Webbing will become damaged at 185°F/85°C.

Focus Track Fall Arrest System Use

The Sapsis Rigging Focus Track System has been provided with a Self Retracting Device (SRD). The purpose of the SRL is to prevent the technician from falling out of the Focus Track chair. ***Read and follow all of the instructions that come with your SRD.***

Please use the following procedures:

- After assembling the Focus Track System and the chair has been installed on the track, connect the SRD to the center beam trolley in the Focus Track Chair assembly.
- Connect the SRD line hook (snap) to the dorsal ring on the technicians' harness. If the harness has a sternum ring, this ring can be used with the SRD instead of the dorsal ring.
- Anyone using the Focus Track chair must be wearing a properly sized fall arrest harness that meets all applicable OSHA regulations and ANSI Z359 standards.
- The technician must be connected to the SRD at all times while in the Focus Track chair.



SRD Inspection Procedures

IMPORTANT - The Focus Track System, including the Fall Arrest components of the system, must be inspected prior to each use. Read and follow all the instructions that come with your SRD equipment

- Inspect the Focus Track chair trolley assembly for abrasion, wear and tear and proper operation as noted above.
- Inspect the carabiner connecting the SRD to the Focus Track fall arrest trolley for abrasion, wear and tear and proper operation.
- Inspect the SRD connection hook (snap) for abrasion, wear and tear and proper operation.
- Inspect the entire length of webbing for wear and tear, cuts or heat related damage. (the polyester webbing will suffer permanent damage at 185° F/85° C).
- Manually check the braking mechanism for proper operation. Operation can be checked by quickly pulling the webbing out of the housing. SRD must lock within 12”.
- All worn or non-functioning equipment must be immediately removed from service and replaced.

Warranty

Sapsis Rigging, Inc. shall repair or replace equipment manufactured, supplied, installed by and/or purchased from Sapsis Rigging, Inc., at no charge to the customer, for a period of three (3) years from the purchase date, if the failure is shown to be caused by manufacturer defects. This warranty does not cover equipment failure due to improper installation (unless installed by Sapsis Rigging, Inc.), or owner/user negligence, abuse, misuse, normal wear, or acts of terrorism



800-727-7471 • www.sapsis-rigging.com • sales@sapsis-rigging.com

870 Bunting Ln Bldg A Primos, PA 19018 •

Inspection/Maintenance Log

DATE	EQUIPMENT	TECHNICIAN	DESCRIPTION/ACTION TAKEN

